

KNG

Niederdruck-Kugelhahn mit Gewindeanschluß
 Low pressure ball valve with threaded ports
 Niskociśnieniowe zawory kulowe z przyłączami gwintowanymi



DN 12-25



DN 4-10

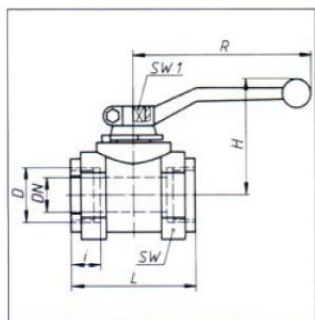

- Mit DIN-DVGW-Anerkennung für Gas (siehe Seite 106-107).
- Der Schaltgriff gehört zum Lieferumfang.
- Bei Kugelhähnen mit Dichtungen aus Teflon werden im Normalfall O-Ringe aus Viton eingebaut.
- Sonderausführungen auf Anfrage.

● With DIN DVGW (DIN standard of the German association of gas and water specialists Deutscher Verein der Gas- und Wasserfachmänner) acceptance for gas (cf. p. 106-107).

- The handle is included.
- Ball valves with teflon seals are normally delivered with viton O-rings.
- Special designs upon request.

● Z dopuszczeniem dla gazu wg DIN DVGW (norma DIN wydana przez Deutscher Verein der Gas- und Wasserfachmänner) (patrz str. 106-107)

- Dźwignia ręczna w komplecie
- Zawory kulowe z uszczelnieniem teflonowym są normalnie dostarczane z o-ringiem z witonu
- Wykonania specjalne na zapytanie

	PN bar	DN mm	Normalausführungen Standard versions Wykonanie standardowe	
			Typ 1	Typ 2
Gehäuse Body Korpus	25	4-25	Stahl Steel Stal	Stahl Steel Stal
Kugel Ball Kula	25	4-25	Messing Brass Mosiądz	Stahl, hartverchromt Steel, hard chromed Stal chromowana
Dichtungen Seals Uszczelnienie	25	4-25	Perbunan	Teflon

Bestell-Nr. und Typ bitte angeben.

Please quote order-no. and typ.

Proszę podać numer zamówieniowy oraz typ.

Typ 1
Typ 2

KNG V025.104 /...

Auch lieferbar mit TÜV-Bauteil-Kennzeichen.





Also available with TÜV piece part mark.

Dostępne także z oznakowaniem TÜV.

Volldurchgang
 Baulänge DIN 3202 V1, M3
 DN 4-25
 PN 25

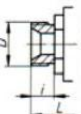
Full bore
 Length, face-to-face DIN 3202 V1, M3
 DN 4-25
 PN 25

Zawór pełnoprzelotowy
 Długość zabudowy wg DIN 3202 V1, M3
 DN 4-25
 PN 25

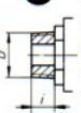
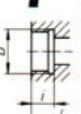
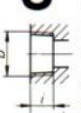
Anschlußart Type of connection Typ przyłącza	DN	Rohr AD pipe OD Ø rury	PN	D	i	L	SW	H	R	SW1	Gew. kg Weight kg Ciężar kg	Bestell-Nr. Order-No. Numer zamówieniowy
1 Für Rohrverschraubung mit Kugelbuchse, DIN 7601  For compression fitting, with ball-type nipple, DIN 7601 Złącze rurowe z tuleją kulową wg DIN 7601	4	-	25	M 12 x 1,5	10	76	24	44	60	8	0,3	KNG V 025.104
	6	-	25	M 14 x 1,5	10	76	24	44	60	8	0,3	KNG V 025.106
	8	-	25	M 16 x 1,5	11	76	24	44	60	8	0,3	KNG V 025.108
	10	-	25	M 18 x 1,5	11	80	30	50	60	8	0,4	KNG V 025.110
	12	-	25	M 22 x 1,5	12	96	36	55	100	10	0,7	KNG V 025.112
	16	-	25	M 26 x 1,5	12	105	41	68	130	10	0,8	KNG V 025.116
	20	-	25	M 30 x 1,5	14	110	46	70	130	10	1,1	KNG V 025.120
	25	-	25	M 38 x 1,5	14	120	55	82	180	12	1,6	KNG V 025.125
2 Für Rohrverschraubung leichte Reihe, DIN 2353  For compression fitting, light series, DIN 2353 Złącze rurowe seria lekka wg DIN 2353	4	6	25	M 12 x 1,5	10	76	24	44	60	8	0,3	KNG V 025.204
	6	8	25	M 14 x 1,5	10	76	24	44	60	8	0,3	KNG V 025.206
	8	10	25	M 16 x 1,5	11	76	24	44	60	8	0,3	KNG V 025.208
	10	12	25	M 18 x 1,5	11	80	30	50	60	8	0,4	KNG V 025.210
	12	15	25	M 22 x 1,5	12	96	36	55	100	10	0,7	KNG V 025.212
	16	18	25	M 26 x 1,5	12	105	41	68	130	10	0,8	KNG V 025.216
	20	22	25	M 30 x 2	14	110	46	70	130	10	1,1	KNG V 025.220
	25	28	25	M 36 x 2	14	120	55	82	180	12	1,6	KNG V 025.225
3 Für Rohrverschraubung schwere Reihe, DIN 2353  For compression fitting, heavy series, DIN 2353 Złącze rurowe seria ciężka wg DIN 2353	4	8	25	M 16 x 1,5	12	76	24	44	60	8	0,3	KNG V 025.304
	6	10	25	M 18 x 1,5	12	76	24	44	60	8	0,3	KNG V 025.306
	8	12	25	M 20 x 1,5	12	76	24	44	60	8	0,3	KNG V 025.308
	10	14	25	M 22 x 1,5	14	80	30	50	60	8	0,4	KNG V 025.310
	12	16	25	M 24 x 1,5	14	96	36	55	100	10	0,7	KNG V 025.312
	16	20	25	M 30 x 2	16	105	41	68	130	10	0,8	KNG V 025.316
	20	25	25	M 36 x 2	18	110	46	70	130	10	1,1	KNG V 025.320
	25	30	25	M 42 x 2	20	120	55	82	180	12	1,6	KNG V 025.325
4 Flachdichtend, metrisches Außengewinde, DIN 13  Flat sealing metric male thread, DIN 13 Gwint zewnętrzny metryczny z uszczelnieniem płaskim wg DIN 13	4	-	25	M 12 x 1,5	10	76	24	44	60	8	0,3	KNG V 025.404
	6	-	25	M 14 x 1,5	10	76	24	44	60	8	0,3	KNG V 025.406
	8	-	25	M 16 x 1,5	11	76	24	44	60	8	0,3	KNG V 025.408
	10	-	25	M 18 x 1,5	11	80	30	50	60	8	0,4	KNG V 025.410
	12	-	25	M 22 x 1,5	12	96	36	55	100	10	0,7	KNG V 025.412
	16	-	25	M 26 x 1,5	12	105	41	68	130	10	0,8	KNG V 025.416
	20	-	25	M 30 x 1,5	14	110	46	70	130	10	1,1	KNG V 025.420
	25	-	25	M 38 x 1,5	14	120	55	82	180	12	1,6	KNG V 025.425
5 Flachdichtend, Rohraußengewinde, DIN ISO 228/1  Flat sealing BSP male thread, DIN ISO 228/1 Gwint zewnętrzny calowy z uszczelnieniem płaskim wg DIN ISO 228/1	4	-	25	G 1/8 A	10	76	24	44	60	8	0,3	KNG V 025.504
	6	-	25	G 1/4 A	11	76	24	44	60	8	0,3	KNG V 025.506
	8	-	25	G 3/8 A	12	76	24	44	60	8	0,3	KNG V 025.508
	10	-	25	G 1/2 A	12	80	30	50	60	8	0,4	KNG V 025.510
	12	-	25	G 3/4 A	12	96	36	55	100	10	0,7	KNG V 025.512
	16	-	25	G 1 A	14	105	41	68	130	10	0,8	KNG V 025.516
	20	-	25	G 1 1/4 A	16	110	46	70	130	10	1,1	KNG V 025.520
	25	-	25	G 1 1/2 A	18	120	55	82	180	12	1,6	KNG V 025.525
6 NPT-Außengewinde, ANSI/ASME B 1.20.1  NPT male thread, ANSI/ASME B 1.20.1 Gwint zewnętrzny skośny NPT wg ANSI/ASME B 1.20.1	4	-	25	NPT 1/8	9,5	69	24	44	60	8	0,3	KNG V 025.604
	6	-	25	NPT 1/4	14,5	79	24	44	60	8	0,3	KNG V 025.606
	8	-	25	NPT 3/8	14,5	79	24	44	60	8	0,3	KNG V 025.608
	10	-	25	NPT 1/2	19	90	30	50	60	8	0,4	KNG V 025.610
	12	-	25	NPT 3/4	19	110	36	55	100	10	0,7	KNG V 025.612
	16	-	25	NPT 1	19	112	41	68	130	10	0,8	KNG V 025.616
	20	-	25	NPT 1 1/4	24	125	46	70	130	10	1,2	KNG V 025.620
	25	-	25	NPT 1 1/2	24,5	141	55	82	180	12	1,7	KNG V 025.625
7 Rohringengewinde, DIN ISO 228/1  BSP female thread, DIN ISO 228/1 Gwint wewnętrzny calowy wg DIN ISO 228/1	4	-	25	G 1/8	11	50	24	44	60	8	0,3	KNG V 025.704
	6	-	25	G 1/4	12,5	50	24	44	60	8	0,3	KNG V 025.706
	8	-	25	G 3/8	12,5	55	28	44	60	8	0,3	KNG V 025.708
	10	-	25	G 1/2	12,5	60	30	50	60	8	0,4	KNG V 025.710
	12	-	25	G 3/4	15	75	36	55	100	10	0,6	KNG V 025.712
	16	-	25	G 1	15	75	41	68	130	10	0,7	KNG V 025.716
	20	-	25	G 1 1/4	18	80	46	70	130	10	0,8	KNG V 025.720
	25	-	25	G 1 1/2	20	90	55	82	180	12	1,2	KNG V 025.725
8 NPT-Innengewinde, ANSI/ASME B 1.20.1  NPT female thread, ANSI/ASME B 1.20.1 Gwint wewnętrzny skośny NPT wg ANSI/ASME B 1.20.1	4	-	25	NPT 1/8	11	50	24	44	60	8	0,3	KNG V 025.804
	6	-	25	NPT 1/4	12,5	50	24	44	60	8	0,3	KNG V 025.806
	8	-	25	NPT 3/8	12,5	55	28	44	60	8	0,3	KNG V 025.808
	10	-	25	NPT 1/2	12,5	60	30	50	60	8	0,4	KNG V 025.810
	12	-	25	NPT 3/4	15	75	36	55	100	10	0,6	KNG V 025.812
	16	-	25	NPT 1	15	75	41	68	130	10	0,7	KNG V 025.816
	20	-	25	NPT 1 1/4	18	80	46	70	130	10	0,8	KNG V 025.820
	25	-	25	NPT 1 1/2	20	90	55	82	180	12	1,2	KNG V 025.825